

E.C.O. Encoder for Hydraulic Cylinders

LINEAR BEARING FOR EXTERNAL AND FRONT APPLICATION

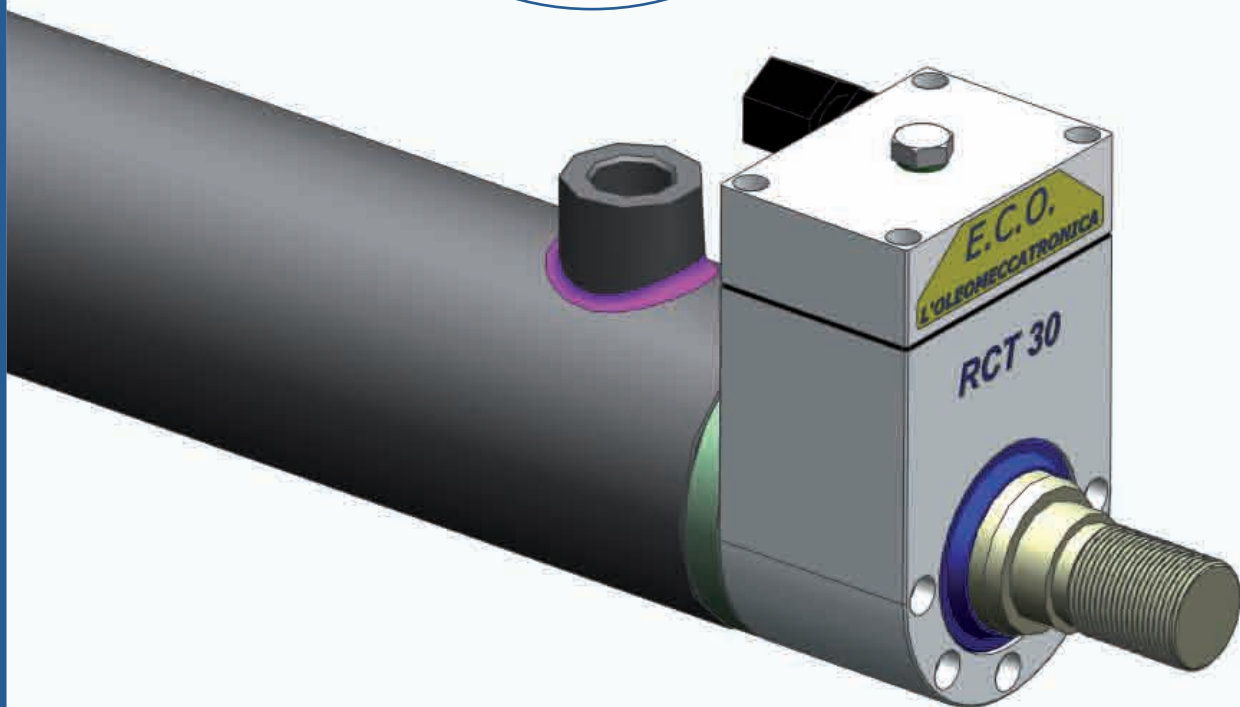

E.C.O. is a position transducer applicable to hydraulic and pneumatic cylinders to detect the continuous position of the rod along its linear mechanical stroke.

It can be installed in its receptacle, anchored externally to the head bush with screws or magnets, or inside the head itself, prepared for the purpose in the design phase. Section **1** shows the operating principle of **E.C.O.**: a micro radial ball bearing suitably preloaded by a spring is dragged by the linear movement of the rod which makes contact with it punctually, and the resulting rotation is detected by a magnet coaxial to the bearing itself. The opposing magnetic encoder acquires the angular position and transmits it to the external control electronics which processes and supplies the linear position of the cylinder rod.

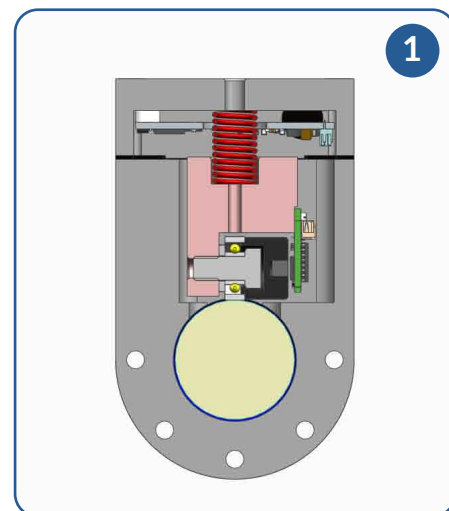

Section **2** shows the perfect axial and radial alignment of the bearing with the center of the rod, obtained with the insertion of two guide pins between the internal parts of the receptacle and the external ones of the fork inserted in it, to guarantee perfect detection of the angular movement of the transduction mechanism.

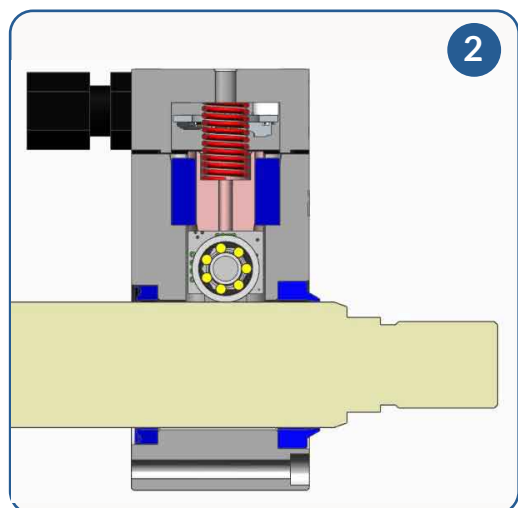

E.C.O. transducer mechanism inserted in the receptacle is external to the cylinder and is not affected by its operating pressures, but is in any case protected from infiltrations and atmospheric agents in the following way:

- a NBR flat seal on the cap/receptacle coupling;
- by a preloaded polyurethane rod seal, to protect against possible leakage from the head bush;
- by a wiper made up of a metal case ring bonded together with polyurethane; alternatively by an ice scraper consisting

of a thin scraper lip in tandem with a NBR/Viton wiping lip encased in a steel shell. After suitable preparation on the receptacle, it is possible to pneumatically pressurize the ice scraper seat if the component is used in particularly harsh environments (foundries, steelworks, shipbuilding...).

But what are the main advantages offered by the application of **E.C.O.**?

- simple and fast applicability on new or existing cylinders, where the front protrusion of the rod allows it;
- single encoder model for all rod diameters and for theoretically infinite linear strokes;
- its operation is not altered by partial rotations of the rod and any minimal traces of fluid present on the rod itself;
- possibility of supplying dual receptacles containing two separate encoders which simultaneously detect the movement of the rod (measurement redundancy, see page 4.00);
- natural applicability on double-rod cylinders;
- applicability in the field of automation in general, to detect linear movements of moving mechanical parts.

TECHNICAL DATA AND FUNCTIONAL PARAMETERS

The following technical data are obtained considering application of **E.C.O.** on a cylinder subjected simultaneously to the three spatial accelerations at a displacement speed of 15 meters per minute.

Longitudinal acceleration **A_x = 15m/s²**

Transversal acceleration **A_y = 10m/s²**

Vertical acceleration **A_z = 15m/s²**

Total weight suspended mass (transduction mech.) 0,22 Kg

Resonance frequency of the system 212 Hz

ROLLING FRICTION AND FORWARD RESISTANCE UNDER LOAD

Bearing average coefficient of friction 0,0015 μ c

Friction torque under maximum applied spring load 0,024 Ca (Nm)

Coefficient of static friction in contact with lubricated rod 0,05 μ s

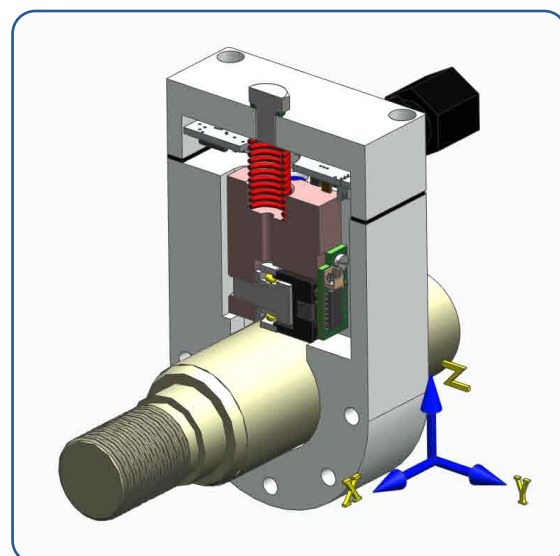

IDEAL SPRING LOAD ON THE MOST UNFAVORABLE ACCELERATION COMBINATION A_x - A_y - A_z

Minimum spring force for dragging without acceleration 60 Fm s (min) (N)

Moment of inertia of the rotating system 7,5E-07 J (kg*m²)

Minimum spring force for dragging with max. acceleration 65 Fm a (N)

Dynamic torque for maximum acceleration 0,0058968Cdin (Nm)

→ It follows that the applied spring load is a function of the application and it can vary from **80N** to **50N**.

DEFORMATION AND HERTZIAN PRESSURE ON Ø20-Ø100mm RODS WITH MAX. SPRING PRELOAD 80N

Ø ROD (mm)	CONTACT AREA (mm ²)	HERTZIAN PRESSURE (N/mm ²)
20	0,0720	1041,70
25	0,0768	976,60
30	0,0792	947,00
40	0,0864	868,00
50	0,0912	822,40
60	0,0936	801,30
70	0,0960	781,25
80	0,1248	601,00
90	0,1480	460,00
100	0,1700	420,00

GEOMETRIC VARIATION OF THE CONTACT AREA

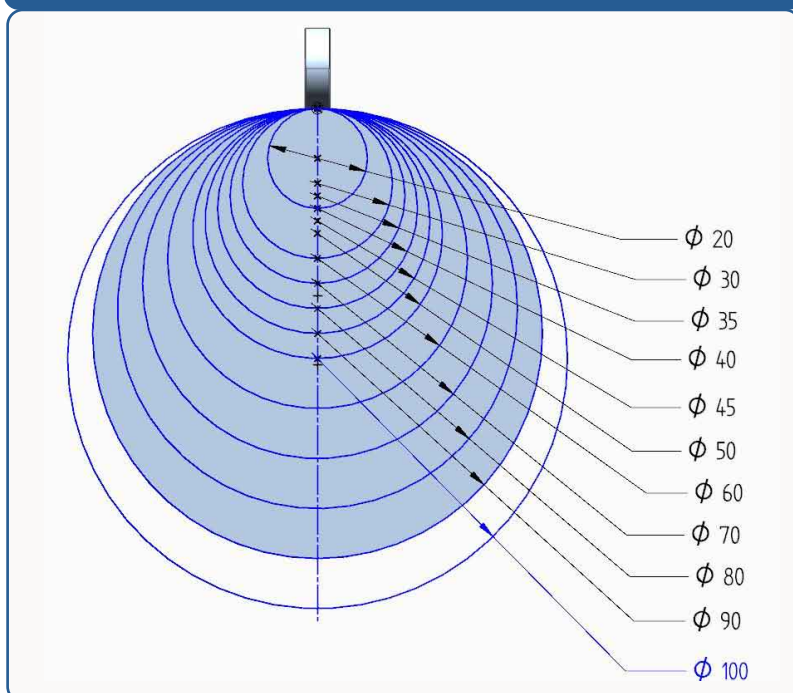

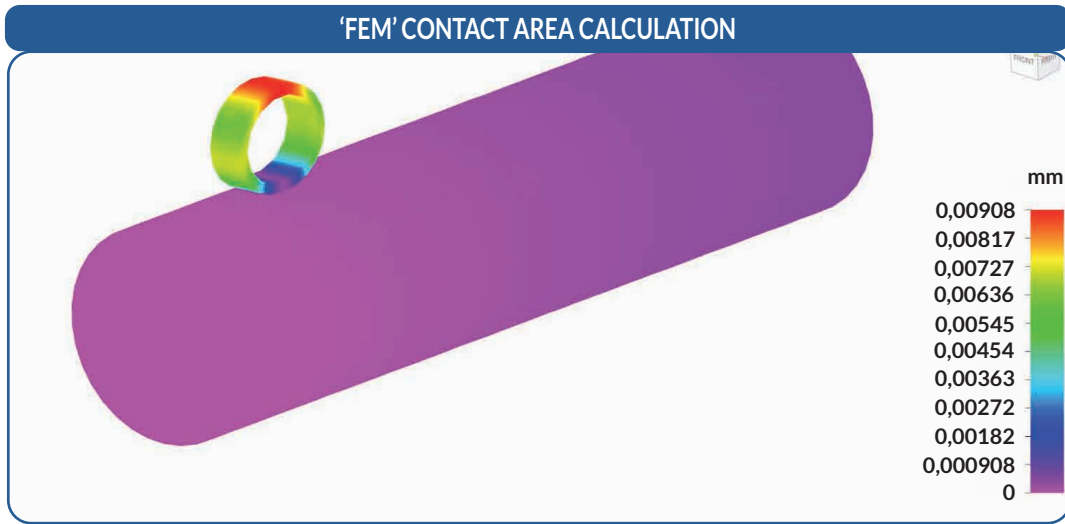

BEARING LIFETIME WITH MAXIMUM SPRING PRELOAD 80N

Ø ROD (mm)	DURATION (km) *	DURATION (km) **	DURATION (km) ***
20	3,5	20	190
25	7,5	38	320
30	9	45	400
40	12	57	450
50	15	76	600
60	22	104	850
70	25	115	1000
80	32	148	1350
90	38	178	1480
100	40	184	1550

* Duration calculated for the beginning of the pitting phenomenon, perfectly efficient system and maximum reliability, bearings with initial cracks underskin.

** Duration calculated with evidence of the pitting phenomenon, system in any case efficient and reliable, bearings with surface scratches.

*** Duration calculated with marked evidence of the pitting phenomenon, less efficient and reliable system, bearings with marked surface scratches.

N.B. Calculations made considering the maximum spring preload 80N, and the maximum contemporary spatial accelerations mentioned on page 2.00: $A_x = 15m/s^2$; $A_y = 10 m/s^2$; $A_z = 15 m/s^2$.

Lower and in any case non-simultaneous accelerations would make it possible to work with a lower spring preload (for example 50N), considerably lengthening the lifetime of the bearing.

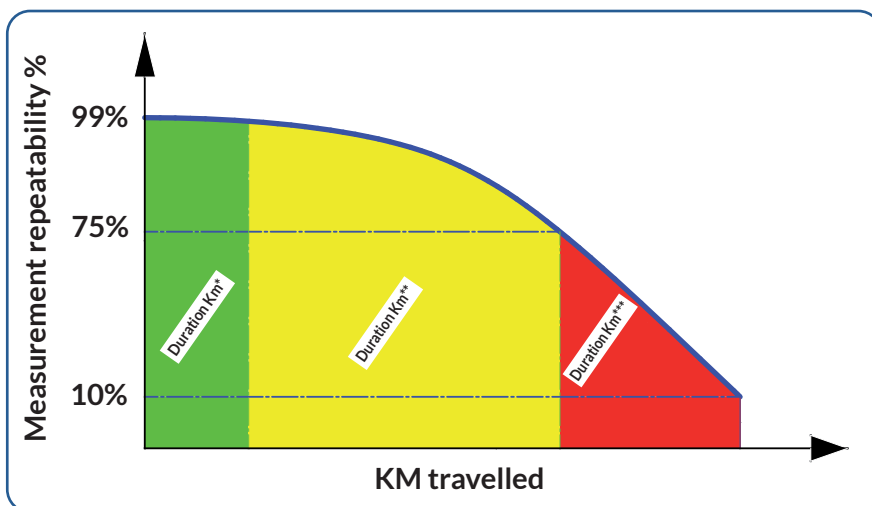

DIGITAL VERSION

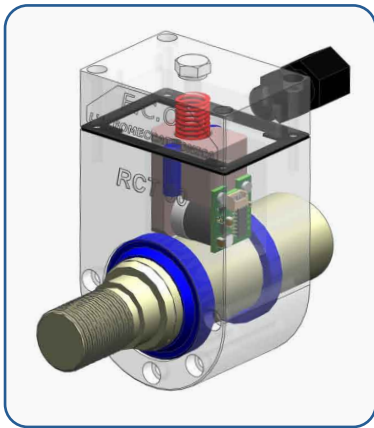

TECHNICAL FEATURES

Rotoconversion of 1 turn: 50,24mm

Programmable resolution as follows:

- 1024 pulses/revolution - 10 bit
- 512 pulses/revolution - 9 bit
- 256 pulses/revolution - 8 bit
- 128 pulses/revolution - 7 bit
- 64 pulses/revolution - 6 bit
- 32 pulses/revolution - 5 bit
- 16 pulses/revolution - 4 bit
- 8 pulses/revolution - 3 bit

Speed/accelerations: depending on the application

Operation temperature: -20°C +80°C

Output electronics: Push-Pull, channels A and B with square waves offset by 90° +/- 15%

Supply: 5/28 VDC

Absorption: 50mA at rest, 150mA under load

ZERO RESET not included

Wiring options

- 1) quadripolar cable L=2mt (IP67 protection degree)
- 2) quadripolar cable L=0,3mt + M12-4 pin male flying connector (IP66/IP67 protection degree)

Protection from short-circuit and polarity inversions

ANALOG VERSION

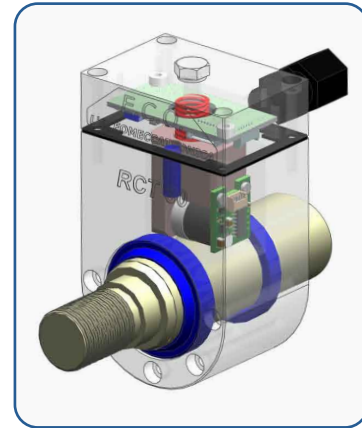

TECHNICAL FEATURES

Rotoconversion of 1 turn: 50,24mm

Theoretical encoder resolution: 4096 pulses/rev. - 12 bit

Speed/accelerations: depending on the application

Operating temperature: -20°C+80°C

Output electronics: 4-20mA/20-4mA; - 0-10V/10-0V

Supply: 5/28 VDC

Absorption: 50mA at rest, 150mA under load

Protection from short-circuit and polarity inversions

Wiring options

- 1) quadripolar cable L=2mt (IP67 protection degree)
- 2) quadripolar cable L=0,3mt + M12-4 pin male flying connector (IP66/IP67 protection degree)

- PIN 1 - +5/28VDC
- PIN 2 - RX SERIAL - DON'T WIRE
- PIN 3 - TX SERIAL - DON'T WIRE
- PIN 4 - OUTPUT 4-20mA/20-4mA
- PIN 5 - OUTPUT 0-10V/10-0V
- PIN 6 - ZERO MARK
- PIN 7 - ZERO RESET
- PIN 8 - GND

M12-4 PIN MALE FLYING CONNECTOR

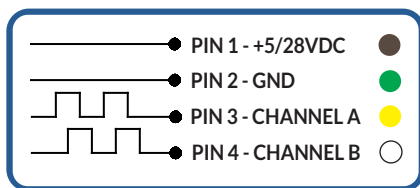
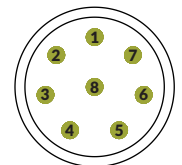

M12-4 PIN MALE FLYING CONNECTOR

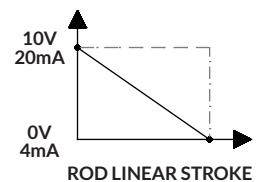
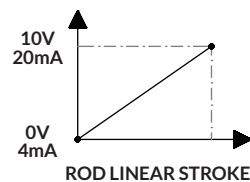
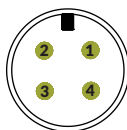

DUAL - REDUNDANT VERSIONS

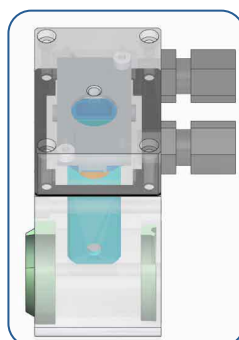
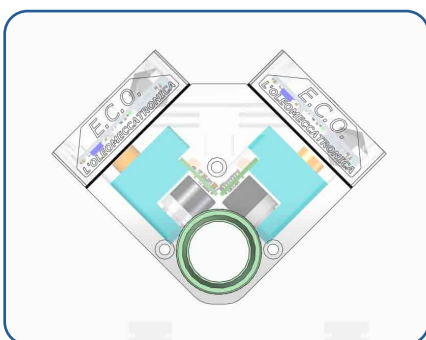

E.C.O. can be supplied in the **dual version** with a "V"-shaped receptacle in which two separate encoder groups are inserted and powered separately, providing a double measurement of the position of the same rod; the receptacle maintains the same longitudinal dimensions as the standard ones, while the possible electronic options are with relative digital or analog output signals.

Possibility of supplying CAN OPEN interface and RS485 RTU with MODBUS protocol.

OVERALL DIMENSIONS FOR RECEPTACLE FROM ROD Ø20mm TO Ø50mm

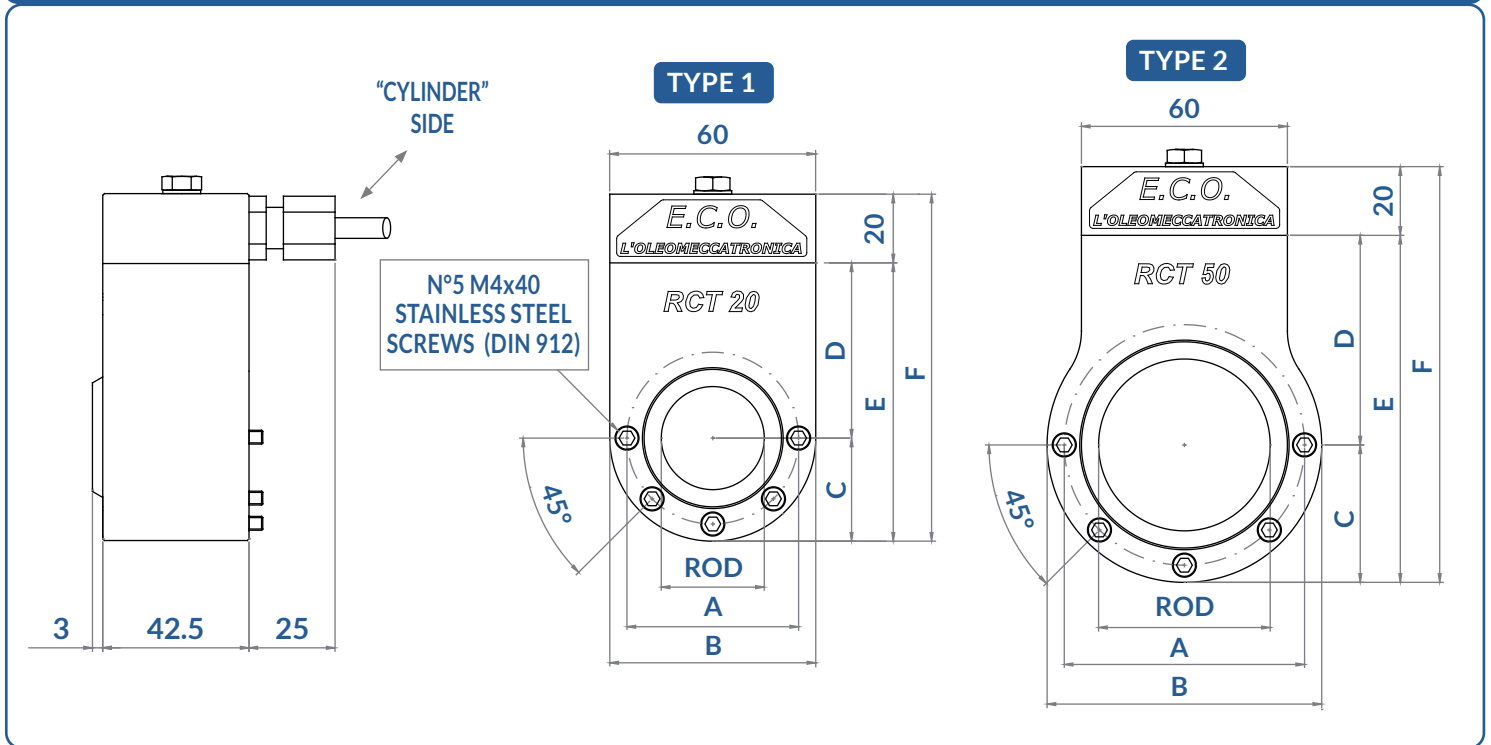

ROD mm	TYPE	A	B	C	D	E	F
Ø20	1	Ø40	60	30	46	76	96
Ø25	1	Ø43.5	60	30	48.5	78.5	98.5
Ø30	1	Ø50	60	30	51	81	101
Ø35	2	Ø53.5	Ø70	35	53.5	88.5	108.5
Ø40	2	Ø60	Ø70	35	56	91	111
Ø45	2	Ø63.5	Ø80	40	58.5	98.5	118.5
Ø50	2	Ø70	Ø80	40	61	101	121

ENCODER BODY AND CLOSING CAP DIMENSIONS

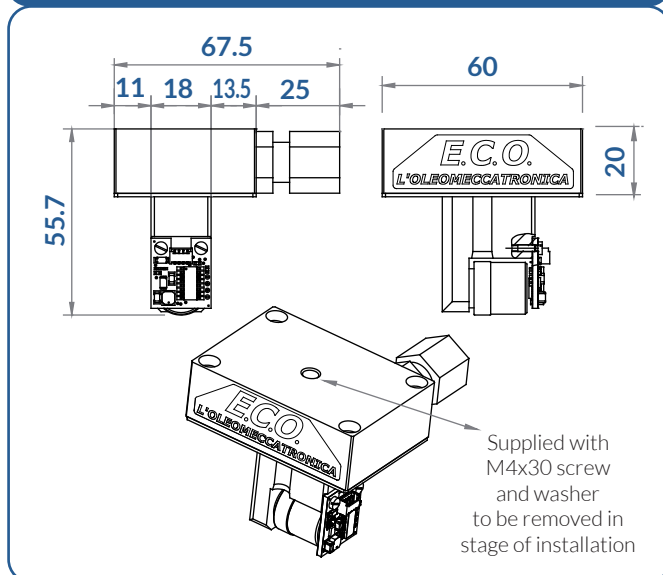

MACHINING FOR APPLICATION ON RECEPTACLE

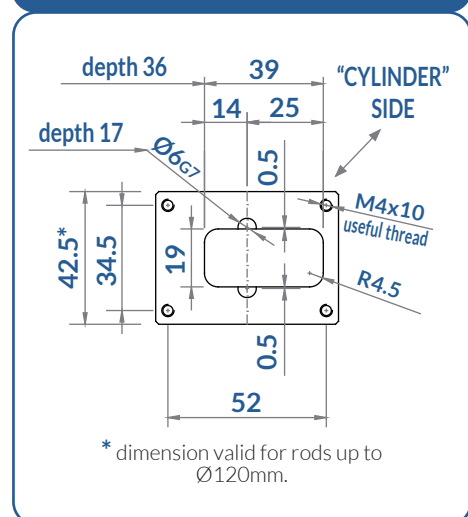



L'Oleomeccatronica s.r.l.s.

Zona Industriale Nord, snc - 06023 Gualdo Tadino (PG) - ITALY

VAT: 03397650544

tel: +39 075 9140079 - info@oleomeccatronica.com

www.oleomeccatronica.com - www.facebook.com/OLEOMECCATRONICA